



Hydraulics 101

Introduction to Hydraulics



GATES

Professional Development

SERIES

Introduction to Hydraulics

Table of Content

The Principles of Hydraulics	Page 2
Where Hydraulic Hose Is Used	Page 5
Hydraulic Sales Opportunities	Page 8
Basics of Hose.....	Page 9
Types of Hose by Operating Pressure.....	Page 11
Gates Hydraulic Hose Dash Numbers and Nomenclature	Page 13
Basics of Couplings	Page 15
Coupling Thread Types.....	Page 17
Hydraulic Crimping Equipment	Page 20
Level 101 Review Quiz.....	Page 22

Principles of Hydraulics

The word “hydraulics” generally refers to power produced by moving liquids. Modern hydraulics is defined as the use of confined liquid to transmit power, multiply force, or produce motion.

Though hydraulic power in the form of water wheels and other simple devices has been in use for centuries, the principles of hydraulics weren't formulated into scientific law until the 17th century. It was then that French philosopher Blaise Pascal discovered that liquids cannot be compressed. He discovered a law which states: Pressure applied on a confined fluid is transmitted in all directions with equal force on equal areas.

To better understand Pascal's Law, let's use a bottle full of liquid as an example. Let's say the bottle has a 1 square inch opening. If we were to apply 10 pounds of force on a cork at the opening, 10 pounds of force would be applied equally to all sides of the bottle. This is expressed as 10 psi or 10 pounds of force per square inch. 10 psi represents the fluid pressure of the system.



The word “hydraulics” generally refers to power produced by moving liquids.



A small force can move a large weight if the small force is moved through a greater distance than the large weight.

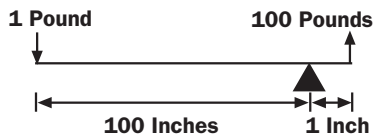

$$1 \text{ lb.} \times 100 \text{ inches} = 100 \text{ lbs.} \times 1 \text{ inch}$$

Though impressive on paper, Pascal's Law wasn't put into practical application until the Industrial Revolution when Joseph Bramah, a British mechanic, built a hydraulic press using pressure, force and confined fluid in a lever-like system.

A closed hydraulic system such as the one diagrammed here provides a mechanical advantage similar to that of a simple lever.

Input Force Output Force

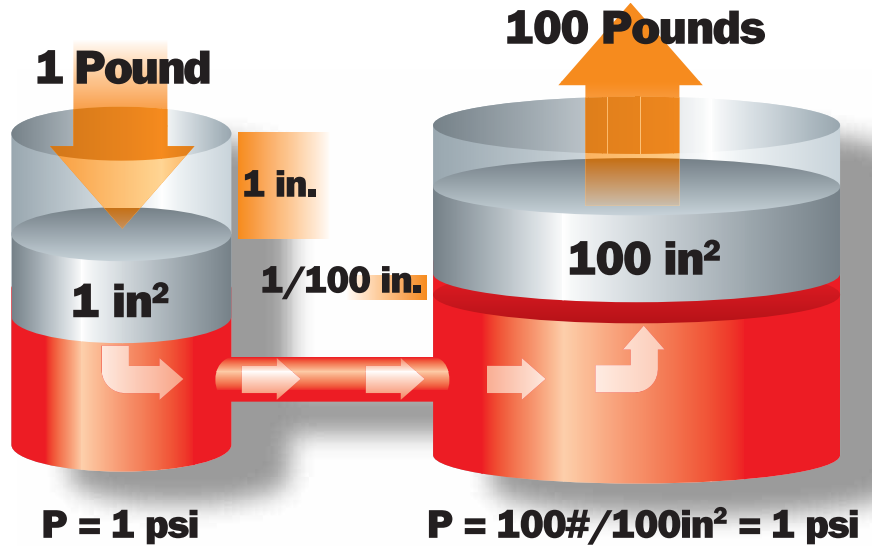

Bramah discovered that in a closed fluid system a small force exerted on a small cylinder could balance a large force on a large cylinder. For example, 1 pound of force applied to a 1 square inch cylinder can balance 100 pounds of force on a 100 square inch cylinder. This is how we can move a 100 pound weight using only 1 pound of force. The distance the 100 pounds will travel is inversely proportional to the distance the applied force travels. That means if we move a 1 square inch cylinder a distance of one inch, we only move the 100 square inch cylinder 1/100th of an inch.

Hydraulic systems contain the following key components:

Fluid - can be almost any liquid. The most common hydraulic fluids contain specially compounded petroleum oils that lubricate and protect the system from corrosion.

Reservoir - acts as a storehouse for the fluid and a heat dissipater.

Hydraulic pump - converts the mechanical energy into hydraulic energy by forcing hydraulic fluid, under pressure, from the reservoir into the system.

Fluid lines - transport the fluid to and from the pump through the hydraulic system. These lines can be rigid metal tubes, or flexible hose assemblies. Fluid lines can transport fluid under pressure or vacuum (suction).

Hydraulic valves - control pressure, direction and flow rate of the hydraulic fluid.

Actuator - converts hydraulic energy into mechanical energy to do work. Actuators usually take the form of hydraulic cylinders. Hydraulic cylinders are used on agricultural, construction, and industrial equipment.



Hydraulic hose has the advantage of transferring power using lightweight components and adds more flexibility when routing transfer lines.

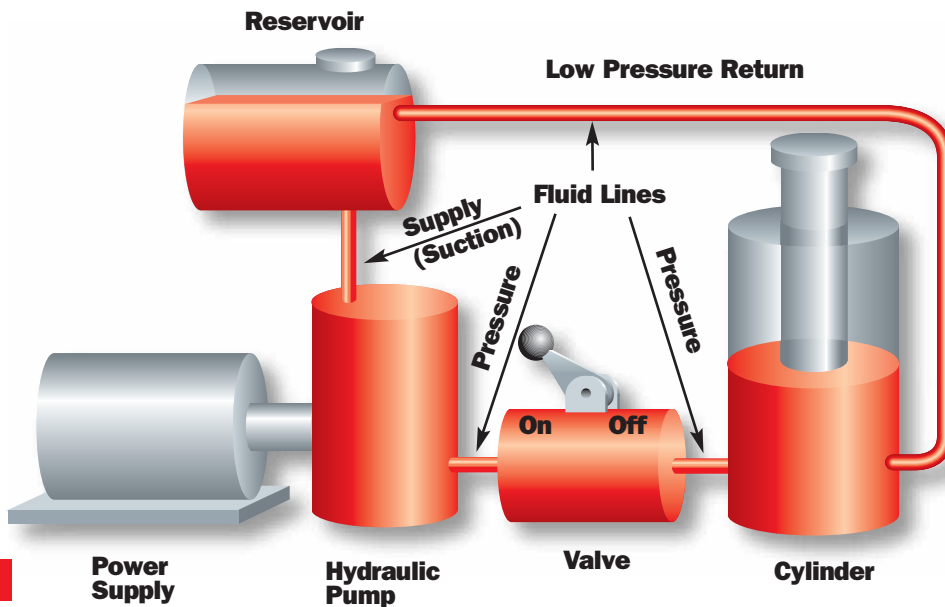

While there are different kinds of pumps, actuators, valves, etc., the basic design of the hydraulic system is essentially the same for all machinery.

Why hydraulic hose? The use of hydraulic machinery gained acceptance in the early 1940s. Around this time, engineers discovered that hydraulic systems needed only minimal space and weight requirements to produce high power output, and these self-lubricating systems protected the metal pipe and tube conductors from rusting.

Eventually, hydraulic hose replaced the metal pipe and tube conductors of these early systems. The rust-resistant hoses were easier to route and install and they added flexibility to moving parts. The hoses were also able to absorb the shock and vibration that typically broke metal tube conductors and could withstand the constant pulsating of hydraulic pumps pushing fluid throughout the system many times per second.

Today, hydraulic hose is the most widely used means of power transmission in the world and can be found almost anywhere. Farm machinery, trucks, buses and virtually all types of earth moving equipment use hydraulic hoses.

Where hydraulic hose is used

Oil & Gas Drilling



Oil & Gas Drilling Rigs

Agricultural Equipment



Combines/Harvesters



Midsize to Large Tractors



Lawn & Garden Tractors

Construction Equipment



Loaders



Hauler Trucks



Cement Trucks



Dozers/Crawlers



Rollers

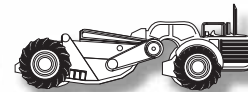

Scrapers



Excavators



Backhoes

Mining Equipment



Dozers/Crawlers



Hauler Trucks



Excavators

Manufacturing Maintenance, Repair, Operations



Fork Lifts

Machine Tools
Injection Molders
Presses
Roof Supports

Where hydraulic hose is used

Fleets

Hydraulic hoses are not exclusive to hydraulic systems. Because of their superior resistance to heat, oil and abrasion, hydraulic hoses are used extensively on trucks, buses and large diesel-powered vehicles. These non-hydraulic applications include connections to turbo chargers, engine and transmission oil coolant lines, diesel fuel, gasoline, air and water lines, plus any other under-the-hood application where a hose is subjected to severe heat, weathering and abrasion.



Because of their superior resistance to heat, oil and abrasion, hydraulic hoses are used extensively on trucks, buses and large diesel-powered vehicles.

Where hydraulic hose is sold

The Gates Rubber Company is a world wide leader in the manufacture of hydraulic hose and couplings. Our key products consist of hose, couplings, adapters, quick disconnects, hydraulic hose crimpers and accessories to these products.

The Distribution Channel

Replacement hydraulic hose and fittings are available from Gates through several distribution channels. These channels are: Automotive Warehouse Distributors, Fleet and Heavy-Duty Distributors, Industrial Hydraulic Specialists, and Original Equipment Dealers. The Automotive Sales Division serves the Automotive Warehouse Distributor and Fleet and Heavy-Duty distribution channels for hydraulic hose and couplings.



The key distribution channels are:
 Industrial Distributors,
 Automotive Warehouse Distributors,
 Fleet & Heavy-Duty Distributors
 and Original Equipment Dealers.

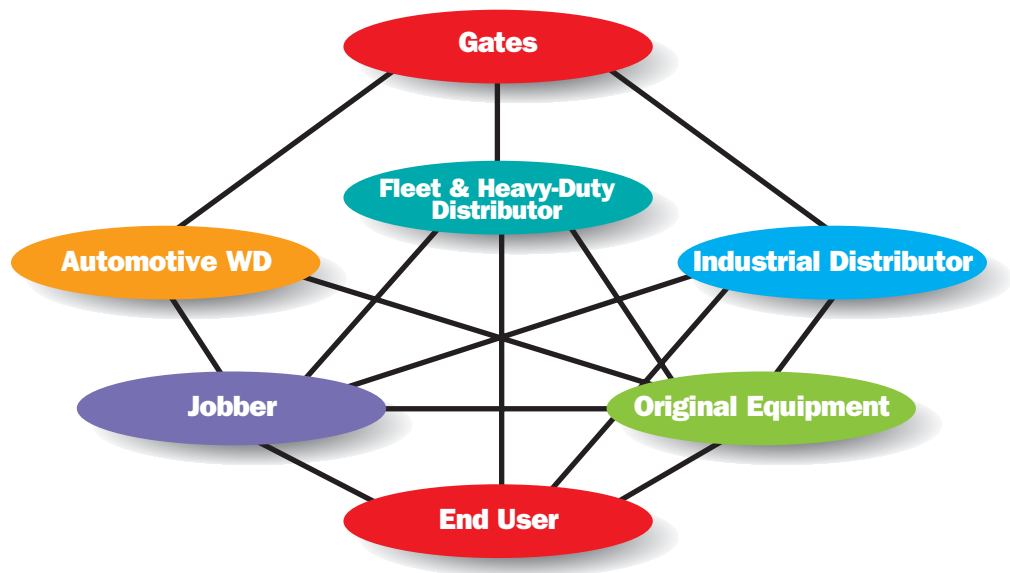

Distributors may fabricate hydraulic assemblies by attaching couplings to hose or they may resell hydraulic hose and couplings for assembly by dealers or end-users. A dealer sells and/or services equipment using hydraulic hose assemblies. End-users may also fabricate assemblies themselves but usually install a pre-made hose assembly onto their equipment.

Hydraulic Sales Opportunities

The following is a list of dealers, fleets, and end-users, by market, that can provide sales opportunities for Gates hydraulic hose and fittings.

- A) Agriculture**
 1. Dairies
 2. Farm equipment dealers
 3. Farm co-ops
 4. Farm repair shops
 5. Hatcheries
 6. Large farms and feedlots
 7. Sod farms
 8. Tree nurseries
- B) Automotive**
 1. Air conditioning repair shops
 2. Car haulers
 3. Car washes
 4. Diesel engine repair shops
 5. Repair shops
- C) Construction**
 1. Asphalt companies
 2. Concrete companies
 3. Earth moving equipment
 4. Large contractors
 5. Logging or saw mills
 6. Mining and quarries
 7. Road and bridge companies
- D) Equipment Dealers**
 1. Construction dealers (John Deere, Case, Komatsu, etc.)
 2. Trenching dealers (Ditch Witch, Vermeer)
 3. Truck equipment dealers (dump bodies, snowplow dealers, etc.)
 4. Turf and landscape equipment dealers (Toro, Jacobsen, etc.)
- E) Government (Local, State, Federal)**
 1. Colleges and Universities
 2. Hospitals
 3. Local and State shops (road, parks, trash departments, electrical, water, bus and transportation departments)
 4. Military installations

- F) Marine**
 1. Boat shops
 2. Ferries
 3. Fishing boats
 4. Marinas
 5. Shipyards
- G) Service and Recreation Industries**
 1. Amusement parks
 2. Equipment rental centers
 3. Golf courses
 4. Landscaping companies
 5. Ski areas
 6. Trash companies
 7. Utility companies
- H) Specialized Areas**
 1. Hardware stores
 2. Hydraulic repair shops (cylinder, pumps, motors, etc.)
 3. Junkyards (metal reclamation)
 4. Tree trimming or removal
 5. Warehouses (fork lifts)
- I) Transportation**
 1. Airports and airlines
 2. Bus lines (tour and commercial)
 3. Railroad construction and track repair
 4. Truck lines
- J) Drilling**
 1. Oil
 2. Gas
 3. Water
 4. Soil samples



Anywhere machines are used to move something you will find an opportunity to sell hydraulic hose.



Hydraulic hose is the lifeline of hydraulic power systems.

Basics of Hose



SAE, DIN and ISO specifications set specific requirements concerning size, tolerances, and minimum performance characteristics for each major hose type.

The vast number of hydraulic applications demand numerous sizes and constructions of hose to satisfy individual working requirements and conditions. Because of this, hydraulic hose varies in weight, size, temperature ratings, numbers and type of reinforcement layers, rated working pressure, flexibility and economics. While there are differences in the end-use of the hose, most hydraulic hoses are built to standards such as SAE (Society of Automotive Engineers), DIN (Deutsch Industrie Norm), and ISO (International Standards Organization). These standards set specific requirements concerning construction, size, tolerance, and minimum performance characteristics for each major hose type. Since these industry standards establish basic, general guidelines and minimum performance ratings, they do not guarantee that all products meeting one standard are completely the same. Details can vary.

Governmental agencies control additional standards for particular industries such as the Mine Safety & Health Administration (MSHA) which sets specifications for flame resistance, the Coast Guard which determines suitability for marine vessel usage, and the Department of Transportation Federal Motor Vehicle Safety Standards (DOT/FMVSS) which sets requirements for hydraulic, air, and vacuum brake hose, hose assemblies and hose end fittings for use on passenger cars, trucks, buses, trailers and motorcycles.

Hydraulic Hose Construction

While there are major differences in the types of hydraulic hoses, there are similarities in construction. Each hose consists primarily of **tube, reinforcement, and cover.**

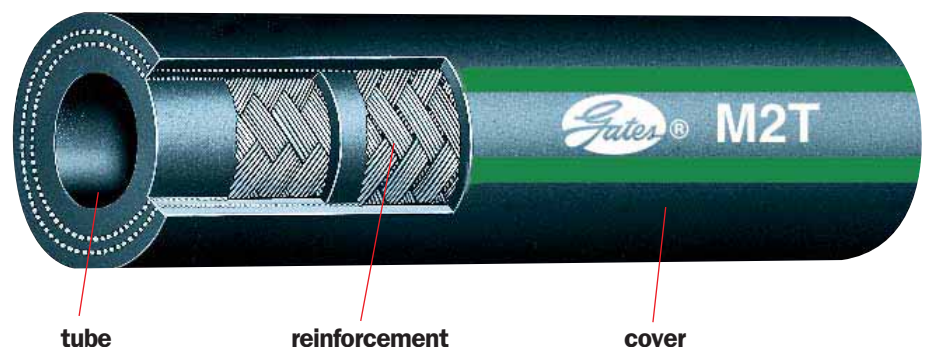

Tube

The tube may be made from many different rubber compounds and composites. The reason for different compounds is to chemically resist the fluid being conveyed. The tube must also resist corrosion, deterioration and the effects of high or low temperatures. The inside diameter (I.D.) of the tube is the key measurement of hose size and must provide the proper volume of fluid for the specific application. Typically, for an SAE specification hose, the smaller the tube's inside diameter, the higher the pressure it can handle.

Reinforcement

The reinforcement is the muscle of all hydraulic hoses. It determines the working pressure of the hose. The reinforcement can be a braid or spiral wrap and can be made of natural fibers, synthetic materials or steel wire. Some hoses use a combination of fiber and steel wire or multiple layers of steel wire braids or spirals.

Cover

The primary purpose of the cover is to protect the tube and reinforcement from heat, abrasion, corrosion and environmental deterioration. The cover can be made from synthetic rubber, fiber braids or a combination of both depending on the application. Hoses with synthetic rubber covers are generally preferred over textile-braid covers because they are more resistant to abrasion. Textile-braid covers are preferred over rubber covers, however, when gases or coolants are conveyed. (Gases migrating through the hose will not cause a textile-braid cover to blister or become separated from the tube). Textile braid covers tend to trap and hold dirt, oil and other contaminants that can deteriorate the hose and shorten its life. Abrasion, which also shortens hose life, occurs from hoses rubbing against each other or metal parts of the equipment. To address this problem, Gates developed MegaTuff® and XtraTuff® hose. They are abrasion-resistant hoses that last longer than standard rubber cover hoses.

Details of the various kinds of materials used in the tube, reinforcement and cover, why they are used, and how they are arranged or formed into hose will be covered in a later training module.



The inside diameter (I.D.) of the tube is the key measurement of hose size.



The reinforcement is the muscle of all hydraulic hoses. It determines the working pressure of the hose.



Gates has a line of abrasion resistant hose that lasts longer than standard rubber cover hose.

Types of Hose by Operating Pressure

Hydraulic hose can be grouped by operating pressure – from extremely high to low. These rankings are based on the operating pressure at a given I.D. For example, a 2” I.D. hose such as 32C12 has an operating pressure of 2500 psi and would be considered very high pressure, whereas a 3/8” I.D. hose such as 6C1T has a 2600 psi operating pressure and would be considered medium pressure.

Understanding the “grouping” of hose by pressure ratings can be confusing. At this point, it is necessary only to be aware of this issue. Hydraulic hoses with the same pressure rating for all sizes simplifies hose selection for equipment hydraulic systems. One hose type does it all. We will discuss hose selection and pressure ratings in depth in a later course.

Very and Extremely High Pressure Hose

Very high and extremely high-pressure hose is used for off-highway equipment and heavy-duty machinery where extremely high impulse (pressure surges) hoses are encountered. The oil-resistant synthetic tubes in these hoses are reinforced with four or six layers of spiraled, high-tensile steel wire over a layer of yarn braid. This spiral reinforcement is particularly well suited to high pressure impulse applications because the individual wires are parallel and each layer is separated by a thin layer of rubber which keeps the wires from cutting one another. Each layer acts independently, leading to more efficient use of the wire strength, increased service life and improved flexibility.

The spiral reinforcement arrangement allows for a more complete coverage of the tube than braid reinforcement, and therefore, more support. Individual ends or strands can be bound tightly together as opposed to the over-under gaps with braiding. What is sacrificed is some flexibility. Braided hose is generally more flexible than spiral hose. Spiral reinforcement is built over the tube in alternating, even-numbered layers to balance the forces of pressure and containment.

These hoses are often called “4-wire” for very high pressure and “6-wire” for extremely high pressure hose, yet actual number of spiral wire layers varies by I.D. Most spiral hose with an I.D. of one inch or less has four layers.



The rated working pressure of a hydraulic hose is the maximum pressure at which the hose is to be used. It is not to be exceeded in any application.

High-Pressure Hose

These hoses are often called “two-wire” braid hose because they generally have a reinforcement of two wire braids of high tensile strength steel. They are frequently found in high-pressure hydraulic applications such as construction equipment. Operating pressures range from 6,000 psi for a 3/16” I.D. to 1825 psi for a 2” I.D. Some proprietary hoses such as M3K have the same pressure rating for all sizes.



Medium-Pressure Hose

These hoses are used for hydraulic applications requiring operating pressures of 300 psi to 3,000 psi. They may be one-wire braid or multiple wire and/or textile braid construction.

In addition to being used on medium-pressure hydraulic equipment, medium-pressure hoses are often used in heavy-duty truck and fleet vehicle applications.

In the early 1940s, there were no flexible hoses on the market designed specifically for the fleet user. Truck mechanics discovered a heavy hose with a high working pressure that was used for hydraulic lines of aircraft and applied it to fleet applications. Soon this hose replaced the rigid copper tubing originally used on trucks.

This truck hose is often called flexline or TWT (textile-wire-textile), but Gates calls this hose C5 hose after its SAE designation of SAE 100R5.



Burst pressure is not a working pressure rating of actual use capability. It is a safety value to cover pressure surges.



C7S/NC and C8S/NC thermoplastic hoses have the same pressure rating as SAE 100R1 and SAE 100R2 hoses respectively. Yet, their constructions are quite different to meet special application needs such as lighter weight, very long lengths, and non-conductivity.

Low-Pressure Hose

Gates markets a variety of low-pressure hydraulic hose. These hoses are designed for use in various applications with operating pressures under 300 psi. Their reinforcement is usually textile. They are used on low-pressure hydraulic equipment or they are used to transmit petroleum-base fluids, diesel fuel, hot lubricating oil, air, glycol anti-freeze and water. Some low-pressure hose such as GMV is also rated for suction applications.



Specialty Hydraulic Hose

Some of these hoses do not fit well into a particular pressure category, but are used in special applications. Examples of special applications are conveying refrigerant or LPG gas, operating at temperature extremes or requiring non-conductivity of electricity.



Hydraulic Hose Dash Numbers and Nomenclature

Hose Size and Dash Numbers

Dash Sizes: The size of a hydraulic hose is based on its inside diameter (I.D.). The I.D. is expressed with a Dash Number. Dash numbers represent the number of 1/16 of an inch segments required to equal the hose I.D. For example, a hose with a 1/4" I.D. can be expressed as 4/16" I.D. which indicates it has four 1/16" segments. Its dash size would be a -4. A hose of 1/2" I.D. (8/16" I.D.) would be a -8. Likewise a 2" hose is a -32 I.D. The dash size precedes the Gates nomenclature to complete the description, however there are exceptions to the dash system. The hoses that are designed to replace tubing are part of this exception. Tubing is measured by its outside diameter (O.D.). A 1/2" O.D. tube has an inside diameter (I.D.) of 13/32". The -8 hose made to replace this tubing has a 13/32" I.D., but is still called -8 or 1/2" I.D. Such dash size exceptions in Gates line are C5C, PolarSeal and C14.



Dash numbers represent the number of 1/16 of an inch segments required to equal the hose I.D.

Definitions for Descriptions

- A = Thick Cover – Skiving Required
- AC = Air Conditioning
- AT = Thin Cover – No Skiving Required
- B = Braid
- C = SAE 100R
- CP = Coal Power
- FLH = Fuel Line
- G = Gates Proprietary
- H = High Temp
- HMP = High Temp Multifluid
- K = Thousands
- J = Jack Hose
- LO = Lock On
- LW = Long Wall
- M = Mega
- NC = Non-Conductive
- RL = Return Line
- S = Spiral
- SHR = Slim Hole Rotary

Example Hose Nomenclature

Gates constant pressure hose families have descriptive names. For example, the **M3K** designation breaks down as follows: The **M** means the hose can be bent twice as tight as standard SAE hose, 3K means the hose has an operating pressure of 3000 pounds per square inch, (“K” is the Roman numeral for 1000).

8 M 3 K

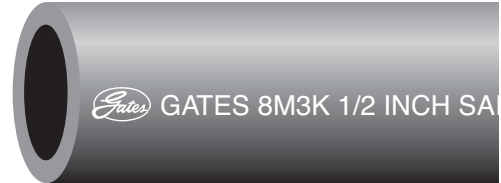

8 M 2 T

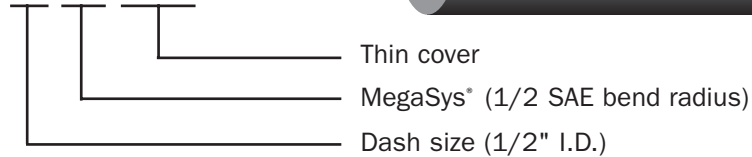

8 C 5 C

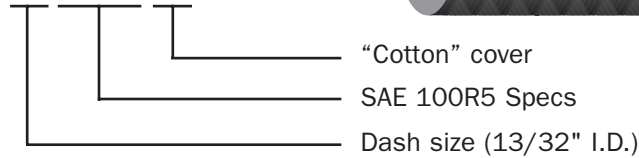

Hose Nomenclature

SAE100R5. For some Gates SAE hoses the letter “C” (Roman numeral for 100) designates the SAE specification. (Example C5 means SAE100R5. The “R” was dropped to shorten the description.)

Basics of Couplings

Couplings provide the means of attaching hose to equipment. They are the metal components teamed with hose to make hydraulic hose assemblies. The stem end of the coupling connects to the hose. The other end, called the thread end, connects the hose assembly to another component in the hydraulic system. Gates coupling descriptions list the hose end first, then the thread end.

There are a variety of ways to attach couplings when making hydraulic hose assemblies. The easiest couplings to install are those used with some special low-pressure hose. These couplings are simply lubricated and pushed into the hose end. As the hose tightens under pressure, the serrations on the coupling grip the hose. This happens because the braid angle is deliberately made larger than neutral (54°). Pressure forces the braid angle to the neutral position causing elongation.

Higher pressure hoses use either reusable or permanent couplings. Reusable (or field attachable couplings) do not require any special equipment to attach to a hose. A collar, called a socket (or ferrule), is screwed on over the hose cover using a wrench. Next the stem is screwed into the tube of the hose using threads on the socket. The stem is wedge-shaped and forces the hose wall out into the female thread cavities. The compression of the hose between the stem and the socket holds the coupling on the hose.

Once reusable couplings were the most popular coupling on the market, but permanent couplings have surpassed them in popularity. Hydraulic assembly-making equipment has made permanent couplings easier and faster to install. Generally, permanent couplings cost less than field attachable couplings.

Permanent Couplings

Permanent couplings require crimping or swaging equipment to attach them to a hose. They are available in either pre-assembled (one-piece) or two-piece configurations. Gates offers both types of couplings: Power Crimp®, GS spiral wire which are two piece and MegaCrimp® which is pre-assembled into one piece.

Pre-assembled (one-piece) couplings are made with the ferrule permanently attached to the stem. Two-piece couplings consist of a stem and separate ferrule. The ferrule is the outside shell that goes over the hose, and the stem is inserted inside the hose. When using two-piece couplings, it is important to match the ferrule with its appropriate stem and hose.

Permanent couplings require special assembly equipment for proper installation. Crimpers apply force perpendicular to the sides of the ferrule. As the coupling is compressed inward, serrations of the ferrule penetrate the hose cover and make contact with the wire reinforcement. This action causes deformation of the hose reinforcement, for a secure, high-quality grip.



Couplings (sometimes called fittings) are the metal components which are teamed with hose to make hydraulic hose assemblies.



Permanent couplings are generally more reliable and therefore the most popular style of coupling in use.



Gates always shows the hose end of a fitting first (on the left) and the thread end last (on the right). Gates descriptions are in the same order (8G- 8MP).

Hose end Thread end

MegaCrimp® Coupling

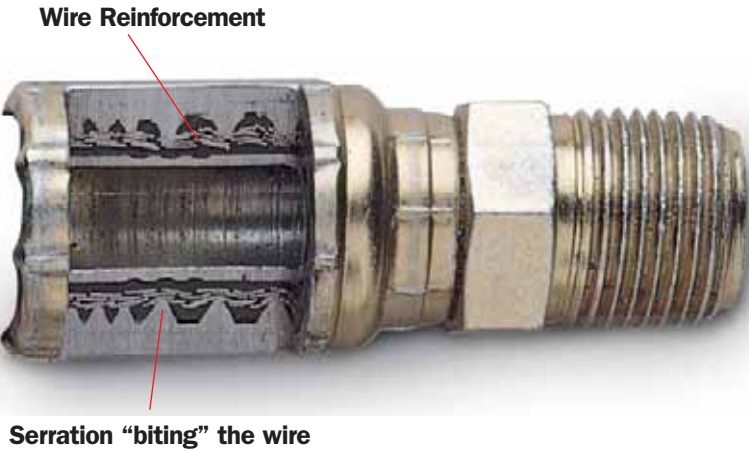

Power Crimp® Coupling

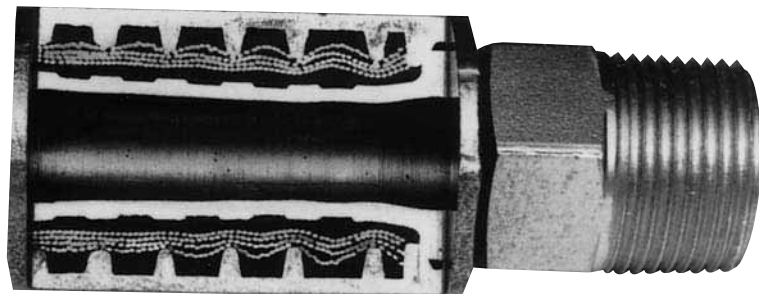

Coupling Thread Types

Thread configurations on couplings come in two types: male (threads outside) and female (threads inside). To establish conformity in the industry, thread ends were standardized. Today there are three principle types of hydraulic seals that thread end designs can conform to: thread seals, mated angle seals and "O"ring seals. The first two use metal-to-metal contact to seal and the latter, "O"rings, use a rubber-to-metal seal.

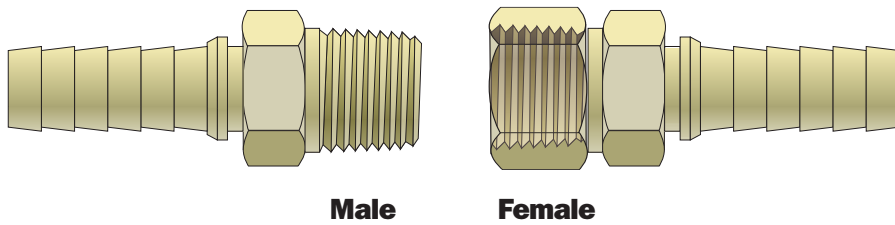

Pipe Thread Seals

There are two types of pipe threads. The first is the National Pipe Tapered for Fuel (NPTF) which features a tapered thread. When male and female components are threaded together, the tapered threads deform and apply pressure on one another which creates the seal. The second is the National Pipe Straight Thread Mechanical Joint (NPSM) which features a straight thread that brings two 30° tapered seats together to form the seal.

In the SAE system, the solid male pipe thread fitting has tapered threads and a 30° seat. The tapered threads are used to create an interference seal when screwed into a solid female port. The 30° seat is used to create the seal with a swivel female pipe's 30° seat.

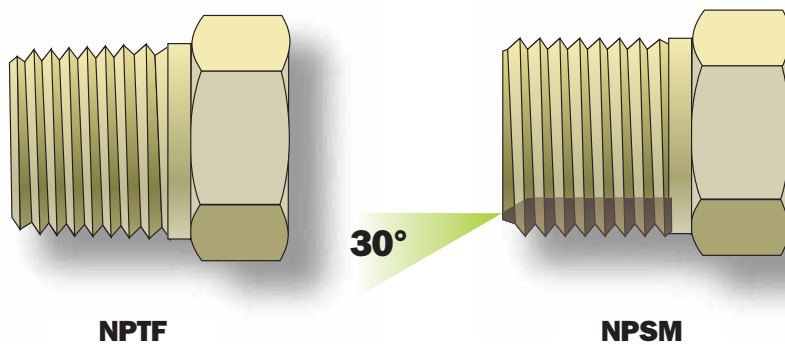

Threads and sealing surfaces conform to one of many industry standards. A few of the more common North American thread end types are introduced here. In a later training module international threads will also be presented.



Couplings with angle seats for sealing have straight or parallel threads. The threads do not seal fluids as with tapered threads. Instead, the threads function to mechanically bring the two mating angle seats together.

Mated Angle Seals

With this design, the hydraulic seal is created when two mated angle surfaces are brought together by the threads. There are two basic types: the **SAE 45°** and the **SAE 37°**. SAE 45° couplings were designed so hose assemblies could be joined to the copper tubing found on early model trucks. Engineers found they could attach a piece of hose by putting a fitting on the tube and then flaring the end of the tube to a 45° angle.

Generally, SAE 45° flare fittings are found on lower pressure applications such as fuel lines, hot oil lines or refrigerant lines. As a rule of thumb, the 45° angle seat is used in “under the hood” and marine applications.

As hydraulic equipment became more powerful and used higher pressures, steel tubing was used instead of copper. A 37° seat angle was adopted because steel tubing could not be flared to an angle greater than 37° without weakening it. Today, 37° angle seats are commonly used on medium and high-pressure lines on heavy equipment to join hydraulic hose assemblies to hydraulic system components.

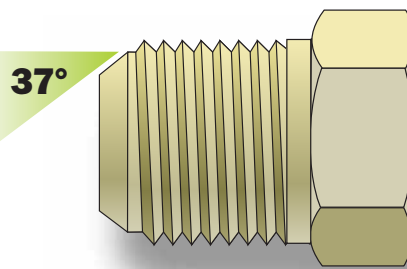

JIC 37°

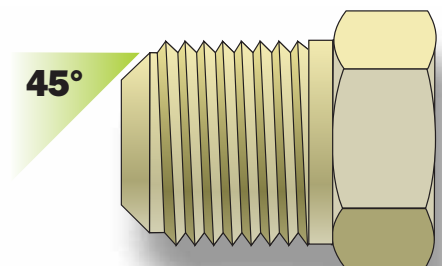

SAE 45°

“O” Ring Seals

There are three basic designs in this family - the “O” Ring Boss, the Flat Face “O” Ring Seal, and the “O” Ring Flange.

In the Boss design, straight threads make the connection while a rubber “O” ring makes the seal. The threads pull the fitting against the port which flattens the ring and forms a seal that is excellent for high-pressure applications.

In the Flat Face “O” Ring Seal (FFOR) a seal is made when the O-ring in the male contacts the flat face on the female. The solid male O-ring face seal fitting will mate with a swivel female O-ring face seal fitting only. The O-ring sits in the O-ring groove in the male.

“O” Ring Flanges solved the problem of making large diameter, high-pressure connections without having to use an extremely large wrench. The port is bored with a center outlet surrounded by a smooth flat face which has four tapped holes and four mounting bolts that tighten down onto flange clamps. There are no threads on the coupling.

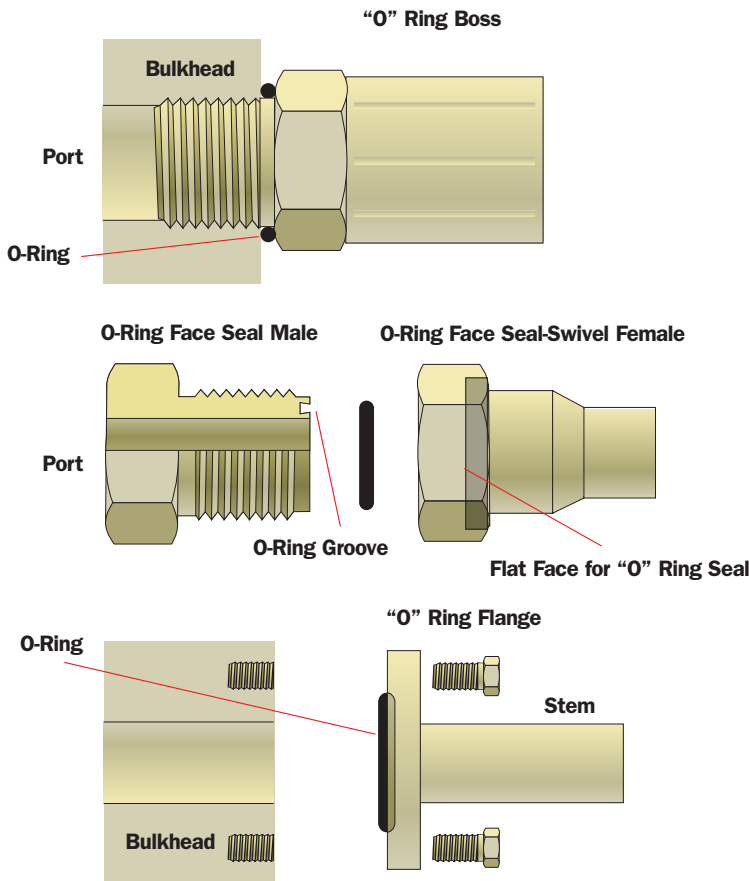

Gates provides tools for measuring and identifying the many different types of thread ends that exist. These tools come in a handy pocket kit that includes a thread specification booklet with the various shapes and measurements necessary for identification.

Adapters

Adapters are threaded metal parts with no direct hose attachment end. Their purpose is to affect a change in thread type, end size or to create a swivel at the port. Adapters will be covered in more detail in a later training module.

Hydraulic Crimping Equipment



Dies are an important part of the crimping process. Different die sets are required depending on the type and size of a hose and the couplings used with it.

Gates supplies four field crimping machines on which factory quality assemblies with permanently attached couplings can be made. Hydraulic assemblies can be fabricated through 1-1/4" I.D. on the PC 707 and MC 4-20, and through 2" I.D. on the OmniCrimp® 21 or PC 3000B. The 206 cutoff saw assures straight, clean cuts.

Dies are an important part of the crimping process. Different die sets are required depending on the type and size of a hose and the couplings used with it. Crimp data charts or die set selection tables should be used to order the proper dies which will be required.

PC 707

The PC 707 is our most popular and versatile crimper. It crimps hoses from 3/16" to 1-1/4" four wire (-20 C12). It can also be modified to become a power swager. It is designed for stationary applications where either 115v or 220v electrical power is available. The digital readout is easy to read and assures factory quality crimps. Bottom load technology allows for excellent visibility and easy insertion of the assembly.



MC 4-20

The MC 4-20 is a light weight portable crimper, weighing only 58 pounds. It crimps 1-1/4" four-wire hose (-20 C12). This crimper is recommended for mobile applications, such as service trucks or where electrical power is not readily available. It can be powered by a variety of sources: hand pump, air pressure, DC electric or AC electric. Customers can choose the pump that best fits their application.



PC 3000B

The PC 3000B is a rugged and economical crimper. The ram can exert a hydraulic force of 125 tons and can crimp all Gates hydraulic hose types, 3/16" to 2" six wire (-32 C13). It uses an automatic limit switch to give push-button convenience during the crimping operation to assure accurate and dependable crimps. This is an economical choice in a two-inch capacity machine. The PC 3000B makes a good companion to the PC 707.





OmniCrimp® 21

The OmniCrimp 21 is our newest state-of-the-art crimper. It is self-contained so there is no need for plumbing hydraulic lines, air bleeding, or special hookups. Everything is included inside the shroud including the pump. It crimps all Gates hydraulic hose types 3/16" to 2" six wire (-32 C13). It features a horizontal front-end feed which makes crimping easier and convenient especially with heavy, large hose assemblies. The unique speed-loading die system is fast and clean, and each die has its own storage cylinder.



Selection of one of these Gates crimpers may depend on such factors as hose size, production rate, portability and cost.



206 Cut-Off Saw

The Power Cutter 206 features a high torque, 4.2 horsepower motor. The front face plate on the 205 saw is designed with movable pins to hold different size hoses. The face plate allows for straight, accurate cuts without binding the saw. It can be used with either a metal blade designed to accurately and cleanly cut braided hose, or an abrasive blade designed to cut spiral hose.

Coupling Cabinet

Each cabinet has four heavy-gauge steel shelves that slide out for easy access. Each shelf holds a combination of ten 3-1/2-inch-wide bin boxes or five 7-inch-wide bin boxes.



Level 101 Review Quiz

1. Modern hydraulics is defined as the use of a confined liquid to transmit power. True or False?
2. Hydraulic hose assemblies absorb shock and vibration inherent to the equipment that they are used on. True or False?
3. The three components used in the construction of most hydraulic hoses are?
 - a.
 - b.
 - c.
4. Which of the following determines the working pressure of a hydraulic assembly?
 - a. cover
 - b. tube
 - c. reinforcement
 - d. coupling
5. Low-pressure hydraulic hoses generally have working pressures below...?
 - a. 100 psi
 - b. 300 psi
 - c. 500 psi
6. What style of hydraulic hose is commonly referred to as flexline or "TWT"?
7. Medium-pressure hydraulic hoses generally have working pressures between 300 psi and 500 psi. True or False?
8. What is the primary purpose of the "cover" on hydraulic hose?

- 9.** “Two-wire” hydraulic hose is commonly referred to as which of the following?
- a. medium pressure
 - b. very high pressure
 - c. extremely high pressure
 - d. none of the above
- 10.** Low-pressure “loc-on” couplings need only to be lubricated and pushed in the hose end for proper performance. True or False?
- 11.** Using Gates nomenclature, write the description for the following hydraulic hose styles:
- a. SAE100R2AT
 - b. SAE100R5
 - c. SAE100R12
 - d. SAE100R13
- 12.** Gates “loc-on” couplings are often made of brass. True or False?
- 13.** The compression of the hose between the stem and socket of high-pressure field attachable couplings holds the coupling on the hose assembly. True or False?
- 14.** Generally, permanent style high-pressure couplings cost more than field-attachable high-pressure couplings. True or False?
- 15.** Name the two types of coupling thread configurations that seal with an O-ring.
- a.
 - b.
- 16.** Name the two types of coupling thread configurations that do not seal with an O-ring.
- a.
 - b.
- 17.** Male couplings always have threads on the “outside.” True or False?

- 18.** What does “FJX” stand for?
- 19.** O-ring flange couplings have various styles of threads. True or False?
- 20.** What are the four field crimping machines that Gates supplies?
- a.
 - b.
 - c.
 - d.
- 21.** What is the hose size range of the following crimpers?
- a. MC 4-20
 - b. PC 3000B
 - c. OmniCrimp 21
 - d. PC 707
- 22.** The size of a hydraulic hose is based on its _____?
- 23.** What does the term “dash size” refer to?
- 24.** What is the inside diameter of a 4C2AT hose?
- 25.** What is the inside diameter of a 4C5C hose?
- 26.** What is the seat angle of the following coupling styles?
- a. SAE
 - b. JIC
- 27.** Name the six basic components of a hydraulic system.
- a.
 - b.
 - c.
 - d.
 - e.
 - f.

Answers

1. True
2. True
3. cover, reinforcement, tube
4. c. reinforcement
5. c. 300 psi
6. C5 hose such as C5C, C5D, C5E
7. False
8. To protect the reinforcement and tube from the environment
9. d. none of the above
10. True
11. a. C2AT b. C5C or C5 c. C12 d. C13
12. True
13. True
14. False
15. O-ring boss or flat face O-ring or flanges
16. pipe or 37 and 45 degree flare
17. True
18. Female JIC 37° flare swivel
19. False
20. MC 4-20, PC 707, OmniCrimp 21, PC 3000B
21. a. 3/16" - 1-1/4" b. 3/16" - 2" c. 3/16" - 2" d. 3/16" - 1-1/4"
22. inside diameter of the tube
23. the inside diameter of the hose's tube expressed as a number which represents number of sixteenths of an inch in the diameter.
24. 1/4 inch
25. 3/16 inch
26. a. 45 degrees b. 37 degrees
27. fluid, reservoir, pump, fluid lines, valves, actuator



The Gates Rubber Company • 900 South Broadway • P.O. Box 5887 • Denver, Colorado 80217-5887
www.gates.com



The Gates Rubber Company • 900 South Broadway • P.O. Box 5887 • Denver, Colorado 80217-5887
www.gates.com